

# Instructions for Use

## RadiForce® GX540-CL

Monochrome LCD monitor

### **Important**









Please read this “Instructions for Use”, and “Installation Manual” (separate volume) carefully to familiarize yourself with safe and effective usage.

Please retain this manual for future reference.

- 
- For monitor adjustment and settings, refer to the “Installation Manual”.
  - For the latest product information including the “Instructions for Use”, refer to our web site :  
<http://www.eizoglobal.com>
-

## SAFETY SYMBOLS

This manual and this product use the safety symbols below. They denote critical information. Please read them carefully.

 <p><b>WARNING</b> Failure to abide by the information in a WARNING may result in serious injury and can be life threatening.</p>	 <p><b>CAUTION</b> Failure to abide by the information in a CAUTION may result in moderate injury and/or property or product damage.</p>
	<p>Indicates an attention to be required. For example, the symbol  illustrates the hazard type such as “the risk of electric shock”.</p>
	<p>Indicates a prohibited action. For example, the symbol  illustrates a particular prohibited action such as “Do not disassemble”.</p>
	<p>Indicates a mandatory action that must be followed. For example, the symbol  illustrates the notification of general prohibition such as “Grounding the unit”.</p>

This product has been adjusted specifically for use in the region to which it was originally shipped. If operated outside this region, the product may not perform as stated in the specifications.

No part of this manual may be reproduced, stored in a retrieval system, or transmitted, in any form or by any means, electronic, mechanical, or otherwise, without the prior written permission of EIZO Corporation.

EIZO Corporation is under no obligation to hold any submitted material or information confidential unless prior arrangements are made pursuant to EIZO Corporation’s receipt of said information. Although every effort has been made to ensure that this manual provides up-to-date information, please note that EIZO monitor specifications are subject to change without notice.

# PRECAUTIONS

## IMPORTANT

- This product has been adjusted specifically for use in the region to which it was originally shipped. If the product is used outside the region, it may not operate as specified in the specifications.
- To personal safety and proper maintenance, please read carefully this section and the caution statements on the monitor.

### Location of the Caution Statements

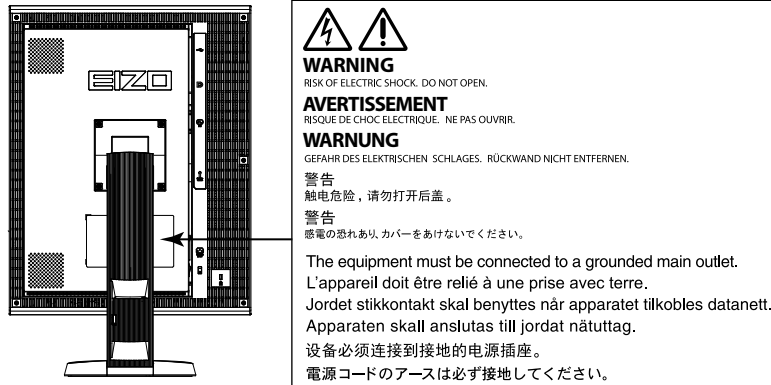

### Symbols on the unit

Symbol	This symbol indicates	
	Main Power Switch:	Press to turn the monitor's main power off.
	Main Power Switch:	Press to turn the monitor's main power on.
	Power button:	Press to turn the monitor's power on or off.
	Alternating current	
	Alerting electrical hazard	
	CAUTION:	Refer to SAFETY SYMBOLS section in this manual.
	WEEE marking:	Product must be disposed of separately; materials may be recycled.
	CE marking:	EU conformity mark in accordance with the provisions of Council Directive 93/42/EEC and 2011/65EU.

## **WARNING**

---

**If the unit begins to emit smoke, smells like something is burning, or makes strange noises, disconnect all power connections immediately and contact your local EIZO representative for advice.**

Attempting to use a malfunctioning unit may result in fire, electric shock, or equipment damage.

---

**Do not open the cabinet or modify the unit.**

Opening the cabinet or modifying the unit may result in fire, electric shock, or burn.



---

**Refer all servicing to qualified service personnel.**

Do not attempt to service this product yourself as opening or removing covers may result in fire, electric shock, or equipment damage.

---

**Keep small objects or liquids away from the unit.**

Small objects accidentally falling through the ventilation slots into the cabinet or spillage into the cabinet may result in fire, electric shock, or equipment damage. If an object or liquid falls/spills into the cabinet, unplug the unit immediately. Have the unit checked by a qualified service engineer before using it again.



---

**Place the unit at the strong and stable place.**

A unit placed on an inadequate surface may fall and result in injury or equipment damage. If the unit falls, disconnect the power immediately and ask your local EIZO representative for advice.

Do not continue using a damaged unit. Using a damaged unit may result in fire or electric shock.



---

**Use the unit in an appropriate location.**

Otherwise, fire, electric shock, or equipment damage may result.

- Do not place outdoors.
- Do not place in any form of transportation (ships, aircraft, trains, automobiles, etc.).
- Do not place in dusty or humid environments.
- Do not place in locations where water may be splashed on the screen (bathrooms, kitchens, etc.)
- Do not place in locations where steam comes in direct contact with the screen.
- Do not place near heat generating devices or humidifiers.
- Do not place in locations where the product is subject to direct sunlight.
- Do not place in an inflammable gas environment.
- Do not place in environments with corrosive gases (such as sulfur dioxide, hydrogen sulfide, nitrogen dioxide, chlorine, ammonia, and ozone).
- Do not place in environments with dust, components that accelerate corrosion in the atmosphere (such as sodium chloride and sulfur), conductive metals, and so on.



---

**To avoid danger of suffocation, keep the plastic packing bags away from babies and children.**

---

**Use the enclosed power cord and connect to the standard power outlet of your country.**

Be sure to remain within the rated voltage of the power cord. Not doing so may result in fire or electric shock.

Power supply: 100-120/200-240Vac 50/60Hz

---

**To disconnect the power cord, grasp the plug firmly and pull.**

Tugging on the cord may damage and result in fire or electric shock.



---

**The equipment must be connected to a grounded main outlet.**

Failure to do so may result in fire or electric shock.



---

**Use the correct voltage.**

- The unit is designed for use with a specific voltage only. Connection to another voltage than specified in this "Instructions for Use" may cause fire, electric shock, or equipment damage.  
Power supply: 100-120/200-240Vac 50/60Hz
  - Do not overload your power circuit, as this may result in fire or electric shock.
-

 **WARNING**

---

**Handle the power cord with care.**

- Do not place the cord underneath the unit or other heavy objects.
- Do not pull on or tie the cord.

If the power cord becomes damaged, stop using it. Use of a damaged cord may result in fire or electric shock.



---

**For the electrical safety, do not connect or disconnect the power cord in the presence of patients.****Never touch the plug and power cord if it begins to thunder.**

Touching them may result in electric shock.



---

**When attaching an arm stand, please refer to the user's manual of the arm stand and install the unit securely.**

Not doing so may cause the unit to become unattached, which may result in injury or equipment damage. Before installation, make sure that desks, walls, and others an arm stand is fixed on have adequate mechanical strength. When the unit is dropped, please ask your local EIZO representative for advice. Do not continue using a damaged unit. Using a damaged unit may result in fire or electric shock. When reattaching the tilt stand, please use the same screws and tighten them securely.

---

**Do not touch a damaged LCD panel directly with bare hands.**

The liquid crystal that may leak from the panel is poisonous if it enters the eyes or mouth. If any part of the skin or body comes in direct contact with the panel, please wash thoroughly. If some physical symptoms result, please consult your doctor.



---

**Fluorescent backlight lamps contain mercury (the products that have LED backlight lamps contain no mercury), dispose according to local, state or federal laws.**

Exposure to elemental mercury can result in effects on the nervous system, including tremor, memory loss, and headache.

---

## CAUTION

---

### Handle with care when carrying the unit.

Disconnect the power cord and cables when moving the unit. Moving the unit with the cord attached is dangerous. It may result in injury.

---

### Carry or place the unit according to the correct specified methods.

- When carrying the unit, grasp and hold firmly as shown in the illustration below.
- Do not unpack or carry the unit only by a single person, since the large size unit is so heavy.

Dropping the unit may result in injury or equipment damage.



### Do not block the ventilation slots on the cabinet.

- Do not place any objects on the ventilation slots.
- Do not install the unit in a closed space.
- Do not use the unit laid down or upside down.

Blocking the ventilation slots prevents proper airflow and may result in fire, electric shock, or equipment damage.



### Do not touch the plug with wet hands.

Doing so may result in electrical shock.



### Use an easily accessible power outlet.

This will ensure that you can disconnect the power quickly in case of a problem.

---

### Periodically clean the area around the plug.

Dust, water, or oil on the plug may result in fire.

---

### Unplug the unit before cleaning it.

Cleaning the unit while it is plugged into a power outlet may result in electric shock.

---

**If you plan to leave the unit unused for an extended period, disconnect the power cord from the wall socket after turning off the power switch for the safety and the power conservation.**

---

**This product is only suitable for a patient environment, but not for contact with a patient.**

---

---

# Notice for this monitor

---

This product is intended to be used in displaying and viewing digital images, including standard and multi-frame digital mammography, for review, analysis and diagnosis by trained medical practitioners. It is specially designed for breast tomosynthesis applications.

**Caution:** Federal law (USA) restricts this device to sale by or on the order of a physician.

---

This product has been adjusted specifically for use in the region to which it was originally shipped. If the product is used outside the region, it may not operate as specified in the specifications.

---

This product may not be covered by warranty for uses other than those described in this manual.

---

The specifications noted in this manual are only applicable when the following are used:

- Power cords provided with the product
  - Signal cables specified by us
- 

Only use optional products manufactured or specified by us with this product.

---

It takes about 30 minutes for the performance of electrical parts to stabilize. Please wait 30 minutes or more after the monitor power has been turned on or the monitor has recovered from the power saving mode, and then adjust the monitor.

---

It takes about a few minutes for the image quality to reach acceptable level. Please wait a few minutes or more after the monitor power has been turned on or the monitor has recovered from the power saving mode, and then view images for diagnosis.

---

Monitors should be set to a lower brightness to reduce changes in luminosity caused by long-term use and maintain a stable display. In addition, perform a calibration and Constancy test (including Grayscale Check) on a periodic basis (refer to “Controlling Monitor Quality” in the Installation Manual).

---

Monitors should be set to a lower brightness to reduce changes in luminosity caused by long-term use and maintain a stable display.

---

When the screen image is changed after displaying the same image for extended periods of time, an afterimage may appear. Use the screen saver or power save function to avoid displaying the same image for extended periods of time.

---

If you place this product on a lacquer-coated desk, the color may adhere to the bottom of the stand due to the composition of the rubber. Check the desk surface before use.

---

Periodic cleaning is recommended to keep the monitor looking new and to prolong its operation lifetime (refer to “Cleaning” (page 8)).

---

The screen may have defective pixels or a small number of light dots on the screen. This is due to the characteristics of the panel itself, and is not a malfunction of the product.

---

The backlight of the LCD panel has a fixed lifetime. When the screen becomes dark or begins to flicker, please contact your local EIZO representative.

---

Do not press on the panel or edge of the frame strongly, as this may result in display malfunctions, such as interference patterns, etc. If pressure is continually applied to the panel, it may deteriorate or damage your panel. (If the pressure marks remain on the panel, leave the monitor with a black or white screen. The symptom may disappear.)

---

---

Do not scratch or press on the panel with any sharp objects, as this may result in damage to the panel. Do not attempt to brush with tissues as this may scratch the panel.

---

When the monitor is cold and brought into a room or the room temperature goes up quickly, dew condensation may occur on the interior and exterior surfaces of the monitor. In that case, do not turn the monitor on. Instead wait until the dew condensation disappears, otherwise it may cause some damage to the monitor.

---

---

## Cleaning

---

### Attention

- Chemicals such as alcohol and antiseptic solution may cause gloss variation, tarnishing, and fading of the cabinet or panel, and also quality deterioration of the image.
  - Never use any thinner, benzene, wax, and abrasive cleaner, which may damage the cabinet or panel.
- 

### Note

- The optional ScreenCleaner is recommended for cleaning the cabinet and panel surface.
- 

The stains on the cabinet and panel surface can be removed by moistening part of a soft cloth with water.

## To use the monitor comfortably

---

- An excessively dark or bright screen may affect your eyes. Adjust the brightness of the monitor according to the environmental conditions.
- Staring at the monitor for a long time tires your eyes. Take a 10-minute rest every hour.



# CONTENTS

<b>PRECAUTIONS</b> .....	<b>3</b>
<b>IMPORTANT</b> .....	<b>3</b>
<b>Notice for this monitor</b> .....	<b>7</b>
Cleaning .....	8
To use the monitor comfortably .....	8
<b>CONTENTS</b> .....	<b>9</b>
<b>Chapter 1 Introduction</b> .....	<b>10</b>
1-1. Features .....	10
1-2. Package Contents .....	11
1-3. EIZO LCD Utility Disk .....	11
● Disk contents and software overview .....	11
● Using RadiCS LE/ScreenManager Pro for Medical .....	11
1-4. Controls and Functions .....	12
<b>Chapter 2 Setting Up</b> .....	<b>13</b>
2-1. Compatible Resolutions .....	13
2-2. Connecting Cables .....	13
2-3. Adjusting the Screen Height and Angle .....	14
<b>Chapter 3 Troubleshooting</b> .....	<b>15</b>
<b>Chapter 4 Specifications</b> .....	<b>17</b>
<b>Chapter 5 Glossary</b> .....	<b>19</b>
<b>Appendix</b> .....	<b>20</b>
Trademark .....	20
License .....	20
Medical Standard .....	21
EMC Information .....	22
FCC Declaration of Conformity .....	27

# Chapter 1 Introduction

Thank you very much for choosing an EIZO monochrome LCD monitor.

## 1-1. Features

- 21.3 inches
- Supports a resolution of 5M pixels (Portrait: 2048 × 2560 dots (H × V))
- Uses high-contrast panel (1200:1).  
Enables the display of sharp images.
- Applicable to DisplayPort (applicable to 8 bit or 10 bit, not applicable to audio signals)
- The Hybrid Gamma function automatically identifies the display area for the medical and other images on the same screen, and displays each set status.
  - \*1 The identification may fail depending on the displayed image. The software to be used needs to be verified. For validation, refer to the Installation Manual (on the CD-ROM).
- The RadiCS SelfQC function and the built-in integrated front sensor allow the user to perform the calibration and Grayscale Check for the monitor independently.  
Refer to the Installation Manual (on the CD-ROM).
  - \*2 When a panel protector (RP-901) is installed, the Integrated Front Sensor cannot be used.
- The CAL Switch function allows the user to select the display mode optimum to the displayed image.
  - The ALT mode adjusts the brightness according to the ambient illuminance.
  - Most suitable mode for calibration  
Refer to the Installation Manual (on the CD-ROM).
- Selectable DICOM (page 19) Part 14 complied screen.
- The quality control software “RadiCS LE” used to calibrate the monitor and to manage the history is included.  
See “1-3. EIZO LCD Utility Disk” (page 11).
- The software “ScreenManager Pro for Medical” to adjust the screen using the mouse and keyboard is included  
See “1-3. EIZO LCD Utility Disk” (page 11).
- Frame Synchronous mode supported (24.5 to 25.5 Hz (DVI signal input only), 49 to 51 Hz)
- Power saving function  
This product is equipped with power saving function.
  - 0 W power consumption when the main power is off  
Equipped with main power switch.  
When the monitor is not required, the power supply can be shut off using the main power switch
  - Presence Sensor  
The sensor on the front side of the monitor detects the movement of a person. When a person moves away from the monitor, the monitor shifts to the power saving mode automatically and does not display the images on the screen.  
Therefore, the function reduces the power consumption.  
Refer to the Installation Manual (on the CD-ROM).
- Long service life LED backlight LCD panel
- Built-in ambient light sensor  
The ambient light sensor can measure the ambient illuminance in lux. Depending on the environment, the sensor sometimes indicates different values from those measured by a stand-alone illuminance meter.  
The built-in ambient light sensor is used in the ALT mode or when the measurement is triggered by user operation in the corresponding menu of the “RadiCS/RadiCS LE” quality control software.  
For further details about the measured value and how to execute the measurement, refer to the RadiCS/RadiCS LE User’s Manual (on the CD-ROM).
- Displays HDCP (High-bandwidth Digital Content Protection) protected contents (DisplayPort only).

**Attention**

- A high temperature or high humidity environment may affect the measurement accuracy of the integrated front sensor. We suggest storing and using the monitor under the following conditions.
  - Temperature 30°C or less
  - Humidity 70% or less
- Avoid storing or using the sensor where it may be exposed to direct sunlight.

## 1-2. Package Contents

Check that all the following items are included in the packaging box. If any items are missing or damaged, contact your local EIZO representative.

**Note**

- Please keep the packaging box and materials for future movement or transport of the monitor.

- Monitor
- Power cord

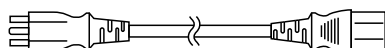

- Digital signal cable: DisplayPort - DisplayPort (PP300)
- Digital signal cable: DVI-D - DVI-D (Dual Link) (DD300DL)

- USB cable: UU300
- EIZO LCD Utility Disk (CD-ROM)
- Instructions for Use (this manual)

## 1-3. EIZO LCD Utility Disk

An “EIZO LCD Utility Disk” (CD-ROM) is supplied with this product. The following table shows the disk contents and the overview of the software programs.

### ● Disk contents and software overview

The disk includes application software programs for adjustment, and Installation Manual. Refer to Readme.txt file on the disk for software startup procedures or file access procedures.

Contents	Overview
Readme.txt file	
RadiCS LE (for Windows)	Quality control software for calibrating the monitor and managing the calibration history.
ScreenManager Pro for Medical (for Windows)	Software for adjusting the screen using the mouse and keyboard.
Installation Manual of this monitor (PDF file)	
“Instructions for Use” of this monitor (PDF file)	

### ● Using RadiCS LE/ScreenManager Pro for Medical

For the installation and use of “RadiCS LE/ScreenManager Pro for Medical”, refer to the respective User’s Manual on the disk.

When using this software, you will need to connect a PC to the monitor with the supplied USB cable. For more information, refer to the Installation Manual (on the CD-ROM).

# 1-4. Controls and Functions

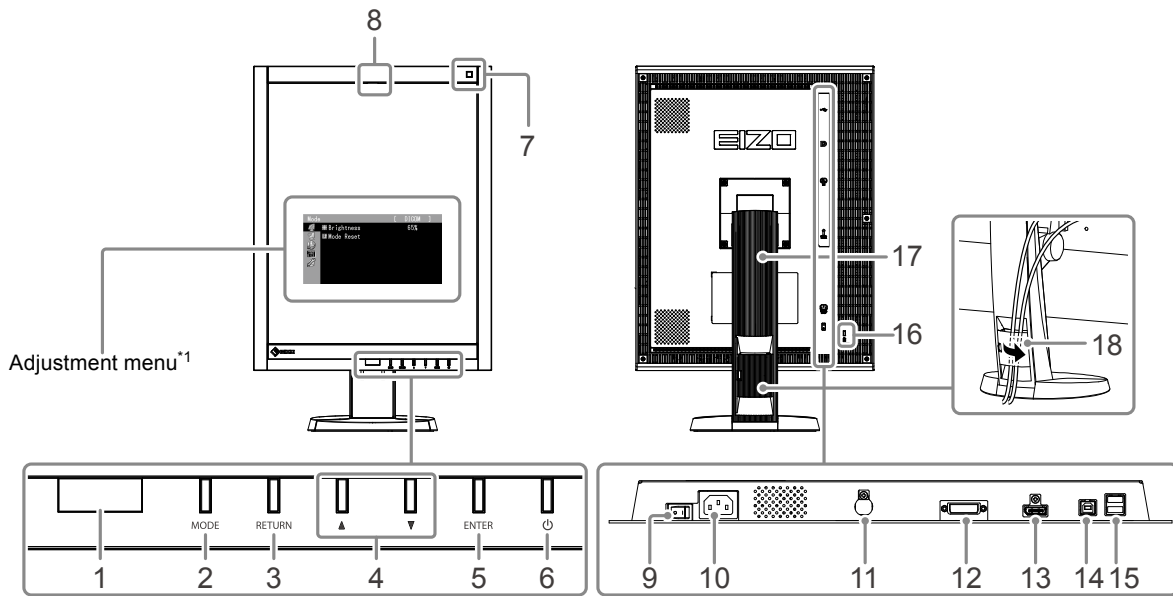

<b>1. Presence Sensor</b>	Detects the movement of a person in front of the monitor.
<b>2. MODE button</b>	Switches the CAL Switch mode.
<b>3. RETURN button</b>	Cancels the setting/adjustment and exits the Adjustment menu.
<b>4. ▲▼ button</b>	Provides the menu selection as well as the adjustment and setting of a function.
<b>5. ENTER button</b>	Displays the Adjustment menu, determines an item on the menu screen, and saves values adjusted.
<b>6. ⏻ button</b>	<ul style="list-style-type: none"> <li>• Turns the power on or off.</li> <li>• Indicates the monitor's operation status. Green: Operating, Orange: Power saving mode, Off: Main power/power off</li> </ul>
<b>7. Ambient Light Sensor</b>	Measures the environmental illumination.
<b>8. Integrated Front Sensor (slide type)</b>	Used for calibration and Grayscale Check.
<b>9. Main power switch</b>	Turns the main power on or off.
<b>10. Power connector</b>	Connects the power cord.
<b>11. PS/2 connector</b>	Used for maintenance. Do not use for other applications. This may cause the monitor to malfunction.
<b>12. Input signal connector</b>	DVI-D connector
<b>13. Input signal connector</b>	DisplayPort connector
<b>14. USB upstream port</b>	Connects the USB cable to use the software that needs USB connection, or to use USB Hub function.
<b>15. USB downstream port</b>	Connects a peripheral USB device.
<b>16. Security lock slot</b>	Complies with Kensington's MicroSaver security system.
<b>17. Stand</b>	Used to adjust the height and angle of the monitor screen.
<b>18. Cable holder</b>	Covers the monitor cables.

\*1 For instructions for use, refer to the Installation Manual (on the CD-ROM).

# Chapter 2 Setting Up

## 2-1. Compatible Resolutions

The monitor supports the following resolutions.

√ : Supported

Resolution	Applicable signal	vertical scan frequency	Dot Clock	DVI		DisplayPort		SDG <sup>*1</sup>
				Portrait	Landscape	Portrait	Landscape	Portrait
720 × 400	VGA TEXT	70 Hz	290 MHz (Max.)	√	√	√	√	√
640 × 480	VGA	60 Hz		√	√	√	√	√
800 × 600	VESA	60 Hz		√	√	√	√	√
1024 × 768	VESA	60 Hz		√	√	√	√	√
1280 × 1024	VESA	60 Hz		√	√	√	√	√
1600 × 1200	VESA	60 Hz		√	√	√	√	√
2560 × 2048	VESA CVT	50 Hz		-	√ <sup>*2</sup>	-	√	-
2048 × 2560	VESA CVT	50 Hz		√ <sup>*2</sup>	-	√	-	-
2560 × 2048	VESA CVT	25 Hz		-	√	-	-	-
2048 × 2560	VESA CVT	25 Hz		√	-	-	-	-
2048 × 2560	SDG	25 Hz		-	-	-	-	√

\*1 A supported graphics board is required to display.

\*2 Dual Link

## 2-2. Connecting Cables

### Attention

- Check that the monitor and the PC are powered off.
- When replacing the current monitor with this monitor, be sure to change the PC settings for resolution and vertical scan frequency to those that are available for this monitor. Refer to the compatible resolution table before connecting the PC.

### Note

- When connecting multiple PCs to this product, refer to the Installation Manual (on the CD-ROM).

### 1. Turn the monitor screen 90° in clockwise direction.

The landscape position is the default monitor orientation. Turn the monitor screen ninety degrees to portrait position before installing it.

### 2. Connect the signal cables to the input signal connectors and PC.

Check the shape of the connectors, and connect the cables.

After connecting the signal cable, tighten the screws of the connectors to secure the coupling.

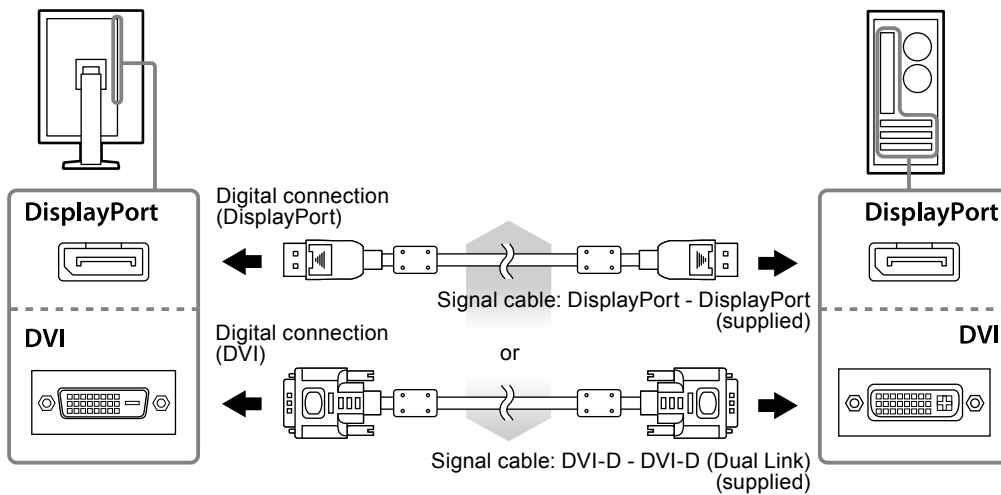

**3. Plug the power cord into a power outlet and the power connector on the monitor.**

**4. Connect the USB cable when using RadiCS LE or ScreenManager Pro for Medical.**

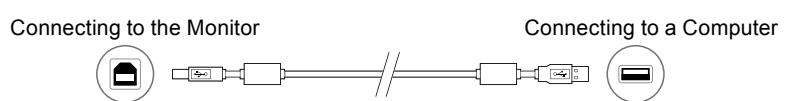

**5. Press  to turn on the monitor.**

The monitor's power indicator lights up green.

**6. Turn on the PC.**

The screen image appears.

If an image does not appear, refer to "Chapter 3 Troubleshooting" (page 15) for additional advice.

**Attention**

- Turn off the monitor and PC after using them.
- For the maximum power saving, it is recommended that the Power button be turned off. Turning off the main power switch or unplugging the power cord completely shuts off power supply to the monitor.

## 2-3. Adjusting the Screen Height and Angle

Hold left and right edge of the monitor with both hands, and adjust the screen height, tilt and swivel of the screen to the best condition for working.

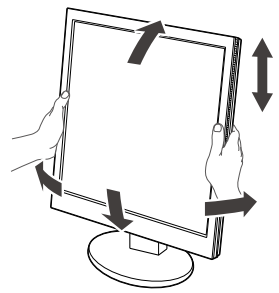

**Attention**

- Be sure that the cables are correctly connected.

# Chapter 3 Troubleshooting

If a problem still remains after applying the suggested remedies, contact your local EIZO representative.

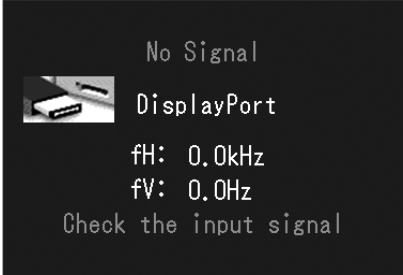
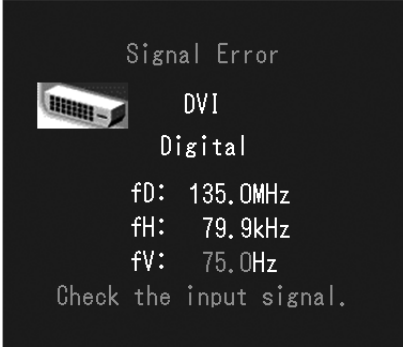
Problem	Possible cause and remedy
<p><b>1. No picture</b></p> <ul style="list-style-type: none"> <li>Power indicator does not light.</li> </ul> <hr/> <ul style="list-style-type: none"> <li>Power indicator is lighting orange and green.</li> </ul> <hr/> <ul style="list-style-type: none"> <li>Power indicator is flashing orange and green.</li> </ul>	<ul style="list-style-type: none"> <li>Check whether the power cord is connected properly.</li> <li>Turn the main power switch on.</li> <li>Press .</li> <li>Turn off the main power, and then turn it on again a few minutes later.</li> </ul> <hr/> <ul style="list-style-type: none"> <li>Switch the input signal. For details, refer to the Installation Manual (on the CD-ROM).</li> <li>Move the mouse or press any key on the keyboard.</li> <li>Check whether the PC is turned on.</li> <li>When Presence Sensor is set to "Auto" or "Manual", the monitor may have shifted to the power saving mode. Come near to the monitor.</li> <li>Turn off the main power, and then turn it on again.</li> </ul> <hr/> <ul style="list-style-type: none"> <li>The device that is connected using DisplayPort have a problem. Solve the problem, turn off the monitor, and then turn it on again. Refer to the User's Manual of the output device for further details.</li> </ul>
<p><b>2. The message below appears.</b></p> <ul style="list-style-type: none"> <li>This message appears when no signal is input. Example:</li> </ul> 	<p>This message appears when the signal is not input correctly even when the monitor functions properly.</p> <ul style="list-style-type: none"> <li>The message shown left may appear, because some PCs do not output the signal soon after power-on.</li> <li>Check whether the PC is turned on.</li> <li>Check whether the signal cable is connected properly.</li> <li>Switch the input signal. For details, refer to the Installation Manual (on the CD-ROM).</li> </ul>
<ul style="list-style-type: none"> <li>The message shows that the input signal is out of the specified frequency range. Example:</li> </ul>  <p>fD: Dot clock fH: Horizontal scan frequency fV: Vertical scan frequency</p>	<ul style="list-style-type: none"> <li>Check whether the PC is configured to meet the resolution and vertical scan frequency requirements of the monitor (see "2-1. Compatible Resolutions" (page 13)).</li> <li>Reboot the PC.</li> <li>Select an appropriate setting using the graphics board's utility. Refer to the manual of the graphics board for details.</li> </ul>

## Error code table

Error Code	Description
0***	<ul style="list-style-type: none"><li>• Errors that occurred during SelfCalibration</li></ul>
1***	<ul style="list-style-type: none"><li>• Errors that occurred during Grayscale Check</li></ul>
*1**	<ul style="list-style-type: none"><li>• Errors that occurred during DICOM</li></ul>
*2**	<ul style="list-style-type: none"><li>• Errors that occurred during CAL1</li></ul>
*3**	<ul style="list-style-type: none"><li>• Errors that occurred during CAL2</li></ul>
**10	<ul style="list-style-type: none"><li>• The product maximum brightness may be lower than the target brightness.</li><li>• Lower the target brightness.</li></ul>
**11	<ul style="list-style-type: none"><li>• The product minimum brightness may be higher than the target brightness.</li><li>• Raise the target brightness.</li></ul>
**34	<ul style="list-style-type: none"><li>• The sensor may not have come out during calibration, or light may have entered the sensor.</li><li>• Turn off the main power, wait for a few minutes before turning the power back on, and then execute SelfCalibration/Grayscale Check again.</li></ul>
**61	<ul style="list-style-type: none"><li>• The sensor may not have come out.</li><li>• Check whether there is any foreign object near the sensor.</li><li>• Execute SelfCalibration/Grayscale Check again.</li></ul>
**95	<ul style="list-style-type: none"><li>• The execution conditions for SelfCalibration/Grayscale Check may not be appropriate.</li><li>• Check the execution conditions and reset them if necessary.</li></ul>



# Chapter 4 Specifications

LCD Panel	Size	21.3-inch (540 mm)	
	Type	TFT monochrome LCD, LED backlight	
	Surface treatment	Anti-glare	
	Surface hardness	2H	
	Viewing angles	Horizontal 176°, vertical 176° (CR≥10)	
	Dot pitch	0.165 mm	
	Response time	Black-white-black: Approx. 25 ms	
Horizontal scan frequency		31-135kHz	
Vertical scan frequency		DVI:	24 - 61 Hz (non-interlace) (VGA TEXT: 69 to 71 Hz, QSXGA (2048 × 2560): 24 to 51 Hz)
		DisplayPort:	49 - 61 Hz (non-interlace) (VGA TEXT: 69 to 71 Hz, QSXGA (2048 × 2560): 49 to 51 Hz)
Resolution		5M pixels (Portrait orientation: 2048 dots × 2560 lines (H × V))	
Max. dot clock		290MHz	
Display grayscales		1,024 steps of 16,369 steps	
Recommended Brightness		500 cd/m <sup>2</sup>	
Display area (H × V)		337.9 mm (13.30 inch) × 422.4 mm (16.63 inch) (Portrait orientation)	
Power supply		100 - 120 Vac ±10%, 50/60 Hz 1.1 - 0.9A 200 - 240 Vac ±10%, 50/60 Hz 0.6 - 0.5A	
Power consumption	Screen display On	108 W or less	
	Power saving mode	0.7 W or less (when only the DVI signal connector is connected, no USB device is connected, "Input Selection" is set to "Manual", "DC5V Output" is set to "Off", and "DP Power Save" is set to "On")	
	Power Off	0.5 W or less (when no USB device is connected, "DC5V Output" is set to "Off", and "DP Power Save" is set to "On")	
	Main power Off	0 W	
Input signal connectors		DVI-D connector	
		DisplayPort connector (Standard V1.1a, applicable to HDCP)	
Digital Signal (DVI) Transmission System		TMDS (Single Link / Dual Link)	
Plug & Play		Digital (DVI-D): VESA DDC 2B / EDID structure 1.3 Digital (DisplayPort) : VESA DisplayPort / EDID structure 1.4	
Dimensions (width) × (height) × (depth)	Main unit	388 mm (15.3 inch) × 512 - 595 mm (20.2 - 23.4 inch) × 245.5 mm (9.7 inch)	
	Main unit (without stand)	388 mm (15.3 inch) × 496 mm (19.5 inch) × 99 mm (3.9 inch)	
Mass	Main unit	Approx. 11.5 kg (25.4 lbs.)	
	Main unit (without stand)	Approx. 8.8 kg (19.4 lbs.)	
Movable range	FlexStand	Tilt:	Up 30°, down 0°
		Swivel:	344°
		Adjustable height:	174 mm (Tilt: 30°), 83 mm (Tilt: 0°)
		Rotation:	90° (counterclockwise for portrait display)
Environmental conditions	Temperature	Operating:	0°C to 35°C (32°F to 95°F)
		Transportation/Storage:	-20°C to 60°C (-4°F to 140°F)
	Humidity	Operating:	20% to 80% R.H. (no condensation)
		Transportation/Storage:	10% to 90% R.H. (no condensation)
	Air pressure	Operating:	700 hPa to 1060 hPa
		Transportation/Storage:	200 hPa to 1060 hPa

USB	Standard	USB Specification Revision 2.0
	Port	Upstream port × 1, Downstream port × 2
	Communication Speed	480 Mbps (high), 12 Mbps (full) 1.5 Mbps (low)
	Supply current	Downstream: Max. 500 mA/1 port

## Outside Dimensions

Unit: mm (inch)

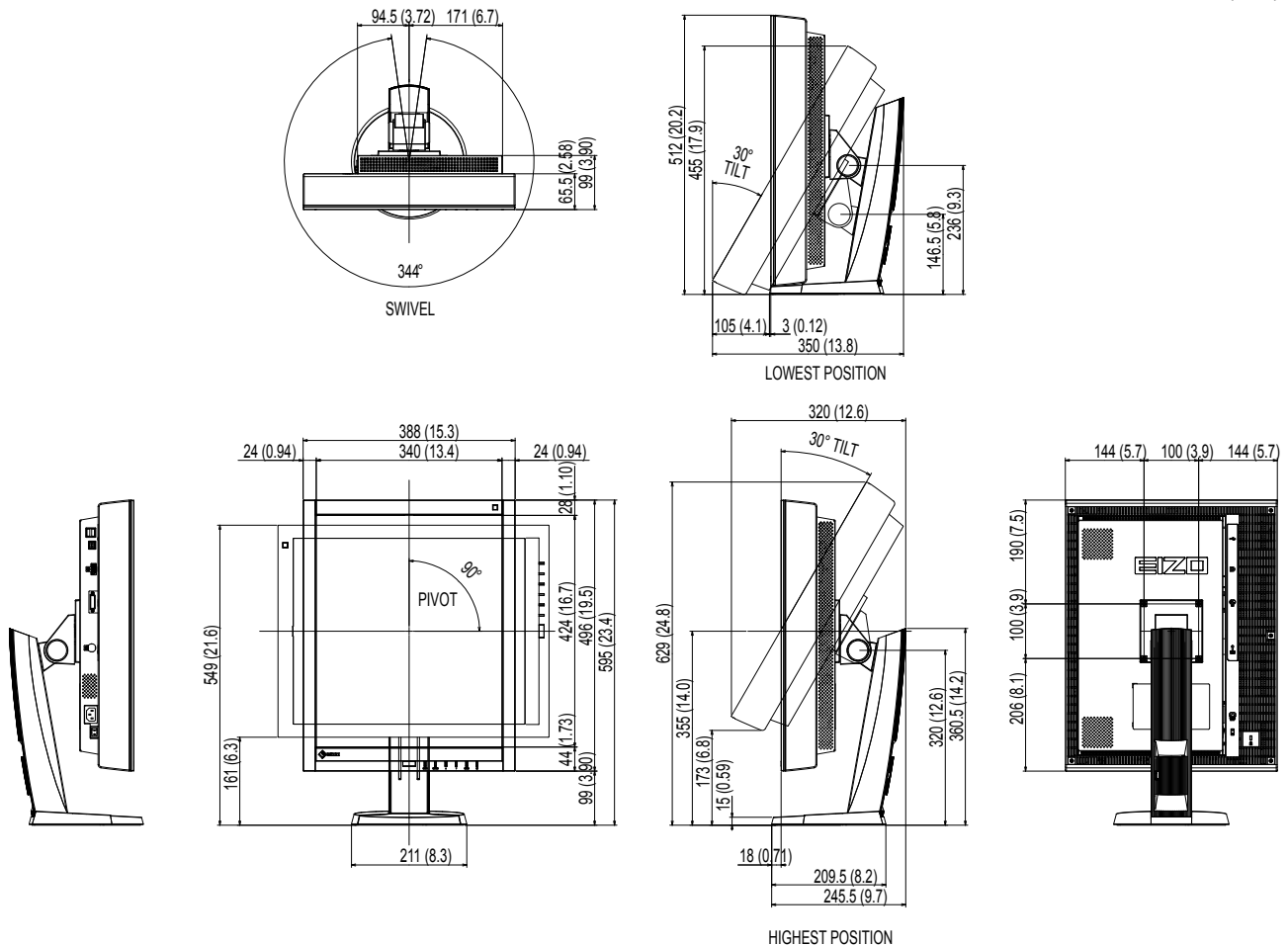

## Accessories

Calibration Kit	EIZO "RadiCS UX1" Ver. 4.1.4 or later EIZO "RadiCS Version Up Kit" Ver. 4.1.4 or later
Network QC Management Software	EIZO "RadiNET Pro" Ver. 4.1.4 or later
Cleaning Kit	EIZO "ScreenCleaner"

For the latest information about the accessories and information about the latest compatible graphics board, refer to our web site.

<http://www.eizo.com>

# Chapter 5 Glossary

## **DDC (Display Data Channel)**

VESA provides the standardization for the interactive communication of the setting information, etc. between a PC and the monitor.

## **DICOM (Digital Imaging and Communication in Medicine)**

The DICOM standard was developed by the American College of Radiology and the National Electrical Manufacturer's Association of the USA.

The DICOM compatible device connection enables to transfer the medical image and information. The DICOM, Part 14 document defines the digital, grayscale medical image display.

## **DisplayPort**

DisplayPort is a next-generation digital AV interface that allows connection of the PC, audio, imaging devices, etc. to the monitor. One cable can transfer sound with images.

## **DVI (Digital Visual Interface)**

DVI is a digital interface standard. DVI allows direct transmission of the PC's digital data without loss. This adopts the TMDS transmission system and DVI connectors. There are two types of DVI connectors. One is a DVI-D connector for digital signal input only. The other is a DVI-I connector for both digital and analog signal inputs.

## **DVI DMPM (DVI Digital Monitor Power Management)**

DVI DMPM is a digital interface power saving function. The "Monitor ON (operating mode)" and "Active Off (power saving mode)" are indispensable for DVI DMPM as the monitor's power mode.

## **HDCP (High-bandwidth Digital Content Protection)**

Digital signal coding system developed to copy-protect the digital contents, such as video, music, etc. This helps to transmit the digital contents safely by coding the digital contents sent via the DVI or HDMI connector on the output side and decoding them on the input side. Any digital contents cannot be reproduced if both of the equipments on the output and input sides are not applicable to HDCP system.

## **Resolution**

The LCD panel consists of numerous pixels of specified size, which are illuminated to form images. This monitor consists of horizontal 2048 pixels and 2560 vertical pixels. At a resolution of 2048 × 2560 (Portrait) and 2560 × 2048 (landscape), all pixels are illuminated as a full screen (1:1).

## **TMDS (Transition Minimized Differential Signaling)**

A signal transmission system for digital interface.

# Appendix

## Trademark

The terms HDMI and HDMI High-Definition Multimedia Interface, and the HDMI Logo are trademarks or registered trademarks of HDMI Licensing, LLC in the United States and other countries.

The DisplayPort Compliance Logo and VESA are registered trademarks of the Video Electronics Standards Association.

Acrobat, Adobe, Adobe AIR, and Photoshop are registered trademarks of Adobe Systems Incorporated in the United States and other countries.

AMD Athlon and AMD Opteron are trademarks of Advanced Micro Devices, Inc.

Apple, ColorSync, eMac, iBook, iMac, iPad, Mac, MacBook, Macintosh, Mac OS, PowerBook, and QuickTime are registered trademarks of Apple Inc.

ColorMunki, Eye-One, and X-Rite are registered trademarks or trademarks of X-Rite Incorporated in the United States and/or other countries.

ColorVision and ColorVision Spyder2 are registered trademarks of DataColor Holding AG in the United States. Spyder3 and Spyder4 are trademarks of DataColor Holding AG.

ENERGY STAR is a registered trademark of the United States Environmental Protection Agency in the United States and other countries.

GRACoL and IDEAlliance are registered trademarks of International Digital Enterprise Alliance.

NEC is a registered trademark of NEC Corporation.

PC-9801 and PC-9821 are trademarks of NEC Corporation.

NextWindow is a registered trademark of NextWindow Ltd.

Intel, Intel Core and Pentium are registered trademarks of Intel Corporation in the United States and other countries.

PowerPC is a registered trademark of International Business Machines Corporation.

PlayStation is a registered trademark of Sony Computer Entertainment Inc.

PSP and PS3 are trademarks of Sony Computer Entertainment Inc.

RealPlayer is a registered trademark of RealNetworks, Inc.

TouchWare is a trademark of 3M Touch Systems, Inc.

Windows, Windows Media, Windows Vista, SQL Server, and Xbox 360 are registered trademarks of Microsoft Corporation in the United States and other countries.

YouTube is a registered trademark of Google Inc.

Firefox is a registered trademark of the Mozilla Foundation.

Kensington and MicroSaver are trademarks of ACCO Brands Corporation.

EIZO, the EIZO Logo, ColorEdge, DuraVision, FlexScan, FORIS, RadiCS, RadiForce, RadiNET, Raptor, and ScreenManager are registered trademarks of EIZO Corporation in Japan and other countries.

ColorNavigator, EcoView NET, EIZO EasyPIX, EIZO ScreenSlicer, i•Sound, Screen Administrator, and UniColor Pro are trademarks of EIZO Corporation.

All other company and product names are trademarks or registered trademarks of their respective owners.

## License

The bitmap font used for this product is designed by Ricoh Industrial Solutions Inc.

# Medical Standard

---

- It shall be assured that the final system is in compliance to IEC60601-1-1 requirement.
- Power supplied equipment can emit electromagnetic waves, that could influence, limit or result in malfunction of the monitor. Install the equipment in a controlled environment, where such effects are avoided.

## Classification of Equipment

- Type of protection against electric shock : Class I
- EMC class: EN60601-1-2:2015 Group 1 Class B
- Classification of medical device (MDD 93/42/EEC) : Class I
- Mode of operation : Continuous
- IP Class : IPX0

# EMC Information

The RadiForce series has a performance that appropriately displays images.

## Environments of Intended Use

The RadiForce series is intended to be used in Professional healthcare facility environments such as clinics and hospitals.

The following environments are not suitable for the RadiForce series to be used:

- Home healthcare environments
- In the vicinity of high-frequency surgical equipments such as electrosurgical knives
- In the vicinity of short-wave therapy equipments
- RF shielded room of the medical equipment systems for MRI
- In shielded location Special environments
- Installed in vehicles including ambulances.
- Other special environment

## WARNING

The RadiForce series requires special precautions regarding EMC and need to be installed. You need to carefully read EMC Information and the “PRECAUTIONS” section in this document, and observe the following instructions when installing and operating the product.

The RadiForce series should not be used adjacent to or stacked with other equipment. If adjacent or stacked use is necessary, the equipment or system should be observed to verify normal operation in the configuration in which it will be used.

When using a portable RF communication equipment, keep it 30 cm (12 inches) or more away from any part, including cables, of the RadiForce series. Otherwise, degradation of the performance of this equipment could result.

Anyone who connects additional equipment to the signal input part or signal output parts, configuring a medical system, is responsible that the system complies with the requirements of IEC/EN60601-1-2.

Be sure to use the cables attached to the product, or cables specified by EIZO.

Use of cables other than those specified or provided by EIZO of this equipment could result in increased electromagnetic emissions or decreased electromagnetic immunity of this equipment and improper operation.

Cables	EIZO Designated Cables	Max. Cable Length	Shielding	Ferrite Core
Signal cable (DisplayPort)	PP300 / PP200	3 m	Shielded	With Ferrite Cores
Signal cable (DVI-D)	DD300DL / DD200DL	3 m	Shielded	With Ferrite Cores
USB cable	UU300 / MD-C93	3 m	Shielded	With Ferrite Cores
Power cord (with earth)	-	3 m	Unshielded	Without Ferrite Cores

## Technical Descriptions

<b>Electromagnetic emissions</b>		
The RadiForce series is intended for use in the electromagnetic environment specified below. The customer or the user of the RadiForce series should assure that it is used in such an environment.		
<b>Emission test</b>	<b>Compliance</b>	<b>Electromagnetic environment - Guidance</b>
RF emissions CISPR11 / EN55011	Group 1	The RadiForce series uses RF energy only for its internal function. Therefore, its RF emission are very low and are not likely to cause any interference in nearby electronic equipment.
RF emissions CISPR11 / EN55011	Class B	The RadiForce series is suitable for use in all establishments, including domestic establishments and those directly connected to the public low-voltage power supply network that supplies buildings used for domestic purposes.
Harmonic emissions IEC / EN61000-3-2	Class D	
Voltage fluctuations / flicker emissions IEC / EN61000-3-3	Complies	

<b>Electromagnetic immunity</b>			
The RadiForce series has been tested at the following compliance levels according to the testing requirements for professional healthcare facility environments defined in IEC / EN60601-1-2. Customers and users of the RadiForce series must ensure that the RadiForce series is used in the following environments:			
<b>Immunity test</b>	<b>Test level for professional healthcare facility environments</b>	<b>Compliance level</b>	<b>Electromagnetic environment - Guidance</b>
Electrostatic discharge (ESD) IEC / EN61000-4-2	±8 kV contact discharge ±15 kV air discharge	±8 kV contact discharge ±15 kV air discharge	Floors should be wood, concrete or ceramic tile. If floors are covered with synthetic material, the relative humidity should be at least 30%.
Electrical fast transients / bursts IEC / EN61000-4-4	±2 kV power lines ±1 kV input / output lines	±2 kV power lines ±1 kV input / output lines	Mains power quality should be that of a typical commercial or hospital environment.
Surges IEC / EN61000-4-5	±1 kV line to line ±2 kV line to ground	±1 kV line to line ±2 kV line to ground	Mains power quality should be that of a typical commercial or hospital environment.
Voltage dips, short interruptions and voltage variations on power supply input lines IEC / EN61000-4-11	0 % $U_T$ (100 % dip in $U_T$ ) 0.5 cycles and 1 cycle 70 % $U_T$ (30 % dip in $U_T$ ) 25 cycles 0 % $U_T$ (100 % dip in $U_T$ ) 5 sec	0 % $U_T$ (100 % dip in $U_T$ ) 0.5 cycles and 1 cycle 70 % $U_T$ (30 % dip in $U_T$ ) 25 cycles 0 % $U_T$ (100 % dip in $U_T$ ) 5 sec	Mains power quality should be that of a typical commercial or hospital environment. If the user of the RadiForce series requires continued operation during power mains interruptions, it is recommended that the RadiForce series be powered from an uninterruptible power supply or a battery.
Power frequency magnetic fields IEC / EN61000-4-8	30 A/m (50 / 60 Hz)	30 A/m	Power frequency magnetic fields should be at levels characteristic of a typical location in a typical commercial or hospital environment. The product should be kept at least 15 cm away from the source of power frequency magnetic fields during use.

<b>Electromagnetic immunity</b>			
<p>The RadiForce series has been tested at the following compliance levels according to the testing requirements for professional healthcare facility environments defined in IEC / EN60601-1-2.</p> <p>Customers and users of the RadiForce series must ensure that the RadiForce series is used in the following environments:</p>			
<b>Immunity test</b>	<b>Test level for professional healthcare facility environments</b>	<b>Compliance level</b>	<b>Electromagnetic environment - Guidance</b>
<p>Conducted disturbances induced by RF fields IEC / EN61000-4-6</p> <p>Radiated RF fields IEC / EN61000-4-3</p>	<p>3 Vrms 150 kHz - 80 MHz</p> <p>6 Vrms ISM bands between 150 kHz and 80 MHz</p> <p>3 V/m 80 MHz - 2.7 GHz</p>	<p>3 Vrms</p> <p>6 Vrms</p> <p>3 V/m</p>	<p>Portable and mobile RF communications equipment should be used no closer to any part of the RadiForce series, including cables, than the recommended separation distance calculated from the equation applicable to the frequency of the transmitter.</p> <p>Recommended separation distance <math>d = 1.2\sqrt{P}</math></p> <p><math>d = 1.2\sqrt{P}</math>, 80 MHz - 800 MHz <math>d = 2.3\sqrt{P}</math>, 800 MHz - 2.7 GHz</p> <p>Where "P" is the maximum output power rating of the transmitter in watts (W) according to the transmitter manufacturer and "d" is the recommended separation distance in meters (m).</p> <p>Field strengths from fixed RF transmitters, as determined by an electromagnetic site survey <sup>a)</sup>, should be less than the compliance level in each frequency range <sup>b)</sup>.</p> <p>Interference may occur in the vicinity of equipment marked with the following symbol.</p> 
Note 1	U <sub>T</sub> is the a.c. mains voltage prior to application of the test level.		
Note 2	At 80 MHz and 800 MHz, the higher frequency range applies.		
Note 3	Guidelines regarding conducted disturbances induced by RF fields or radiated RF fields may not apply in all situations. Electromagnetic propagation is affected by absorption and reflection from structures, objects and people.		
Note 4	The ISM bands between 150 kHz and 80 MHz are 6.765 MHz to 6.795 MHz, 13.553 MHz to 13.567 MHz, 26.957 MHz to 27.283 MHz, and 40.66 MHz to 40.70 MHz.		
a)	Field strengths from fixed transmitters, such as base stations for radio (cellular/cordless) telephones and land mobile radios, amateur radio, AM and FM radio broadcast and TV broadcast cannot be predicted theoretically with accuracy. To assess the electromagnetic environment due to fixed RF transmitters, an electromagnetic site survey should be considered. If the measured field strength in the location in which the RadiForce series is used exceeds the applicable RF compliance level above, the RadiForce series should be observed to verify normal operation. If abnormal performance is observed, additional measures may be necessary, such as reorienting or relocating the RadiForce series.		
b)	Over the frequency range 150 kHz to 80 MHz, field strengths should be less than 3 V/m.		



## Recommended separation distances between portable or mobile RF communication equipment and the RadiForce Series

The RadiForce series is intended for use in an electromagnetic environment in which radiated RF disturbances are controlled. The customer or the user of the RadiForce series can help prevent electromagnetic interference by maintaining a minimum distance between portable and mobile RF communications equipment (transmitters) and the RadiForce series.

Immunity to proximity fields from following RF wireless communication equipments has been confirmed:

Test frequency (MHz)	Bandwidth <sup>a)</sup> (MHz)	Service <sup>a)</sup>	Modulation <sup>b)</sup>	Maximum power (W)	Minimum separation distance (m)	IEC / EN60601 test level (V/m)	Compliance level (V/m)
385	380 - 390	TETRA 400	Pulse modulation <sup>b)</sup> 18 Hz	1.8	0.3	27	27
450	430 - 470	GMRS 460, FRS 460	FM ±5 kHz deviation 1 kHz sine	2	0.3	28	28
710 745 780	704 - 787	LTE Band 13, 17	Pulse modulation <sup>b)</sup> 217 Hz	0.2	0.3	9	9
810 870 930	800 - 960	GSM 800 / 900, TETRA 800, iDEN 820 CDMA 850, LTE Band 5	Pulse modulation <sup>b)</sup> 18 Hz	2	0.3	28	28
1720 1845 1970	1700 - 1990	GSM 1800; CDMA 1900; GSM 1900; DECT; LTE Band 1, 3, 4, 25; UMTS	Pulse modulation <sup>b)</sup> 217 Hz	2	0.3	28	28
2450	2400 - 2570	Bluetooth, WLAN, 802.11 b/g/n, RFID 2450, LTE Band 7	Pulse modulation <sup>b)</sup> 217 Hz	2	0.3	28	28
5240 5500 5785	5100 - 5800	WLAN 802.11 a/n	Pulse modulation <sup>b)</sup> 217 Hz	0.2	0.3	9	9
a)	For some services, only the uplink frequencies are included.						
b)	Carrier waves are modulated using a 50 % duty cycle square wave signal.						

The RadiForce series is intended for use in an electromagnetic environment in which radiated RF disturbances are controlled. For other portable and mobile RF communication equipments (transmitters), minimum distance between portable and mobile RF communications equipment (transmitters) and the RadiForce series as recommended below, according to the maximum output power of the communications equipment.

Rated maximum output power of transmitter (W)	Separation distance according to frequency of transmitter (m)		
	150 kHz to 80 MHz $d = 1.2\sqrt{P}$	80 MHz to 800 MHz $d = 1.2\sqrt{P}$	800 MHz to 2.7 GHz $d = 2.3\sqrt{P}$
0.01	0.12	0.12	0.23
0.1	0.38	0.38	0.73
1	1.2	1.2	2.3
10	3.8	3.8	7.3
100	12	12	23

For transmitters rated at a maximum output power not listed above, the recommended separation distance “d” in meters (m) can be estimated using the equation applicable to the frequency of the transmitter, where “P” is the maximum output power rating of the transmitter in watts (W) according to the transmitter manufacturer.

Note 1	At 80 MHz and 800 MHz, the separation distance for a higher frequency range applies.
Note 2	These guidelines may not apply in all situations. Electromagnetic propagation is affected by absorption and reflection from structures, objects and people.

# FCC Declaration of Conformity

For U.S.A. , Canada, etc. (rated 100-120 Vac) Only

## FCC Declaration of Conformity

**We, the Responsible Party**

EIZO Inc.

5710 Warland Drive, Cypress, CA 90630

Phone: (562) 431-5011

**declare that the product**

Trade name: EIZO

Model: RadiForce GX540

**is in conformity with Part 15 of the FCC Rules. Operation of this product is subject to the following two conditions: (1) this device may not cause harmful interference, and (2) this device must accept any interference received, including interference that may cause undesired operation.**

This equipment has been tested and found to comply with the limits for a Class B digital device, pursuant to Part 15 of the FCC Rules. These limits are designed to provide reasonable protection against harmful interference in a residential installation. This equipment generates, uses, and can radiate radio frequency energy and, if not installed and used in accordance with the instructions, may cause harmful interference to radio communications. However, there is no guarantee that interference will not occur in a particular installation. If this equipment does cause harmful interference to radio or television reception, which can be determined by turning the equipment off and on, the user is encouraged to try to correct the interference by one or more of the following measures.

- \* Reorient or relocate the receiving antenna.
- \* Increase the separation between the equipment and receiver.
- \* Connect the equipment into an outlet on a circuit different from that to which the receiver is connected.
- \* Consult the dealer or an experienced radio/TV technician for help.

Changes or modifications not expressly approved by the party responsible for compliance could void the user's authority to operate the equipment.

### Note

Use the attached specified cable below or EIZO signal cable with this monitor so as to keep interference within the limits of a Class B digital device.

- AC Cord
- Shielded Signal Cable (enclosed)

## Canadian Notice

This Class B digital apparatus complies with Canadian ICES-003.

Cet appareil numérique de la classe B est conforme à la norme NMB-003 du Canada.



## **EIZO Corporation**

153 Shimokashiwano, Hakusan, Ishikawa 924-8566 Japan

## **艺卓显像技术(苏州)有限公司**

中国苏州市苏州工业园区展业路 8 号中新科技工业坊 5B

EC REP



## **EIZO GmbH**

Carl-Benz-Straße 3, 76761 Rülzheim, Germany

<http://www.eizoglobal.com>

Copyright © 2013-2019 EIZO Corporation. All rights reserved.



00N0L834D1   
IFU-GX540-4 

4th Edition-May, 2019 Printed in Japan.